

Thank you for purchasing this Dynojet kit. This kit has been developed for a motorcycle which is set to the parameters listed at the right in the "Stage" description. If your motorcycle does not meet any of these parameters please check with Dynojet before installation. For technical assistance contact your Dynojet distributor or call Dynojet U.S.A. (800)-992-4993

2191 Mendenhall Dr. Suite 105
 North Las Vegas, NV 89081
 TEL: 702-399-1423
 FAX: 702-399-1431
 8am-5pm Pacific Time
 Monday through Friday

Website Address
<http://www.dynojet.com>

The manufacturer and seller make no warranties express or implied which extend beyond the description of the goods contained herein. Any description of this product is for the purpose of identifying it and shall not be deemed to create an express warranty.



2107.003

U.S. Models Only

1982-83 Kawasaki GPZ550

Stage 1&3

STAGE 1

For mildly tuned machines using the stock airbox, with stock or K&N filter #KA-1700

STAGE 3

For mildly tuned machines using individual filters or velocity stacks. K&N filters #RC-1824

Both stages may be used with a good aftermarket exhaust

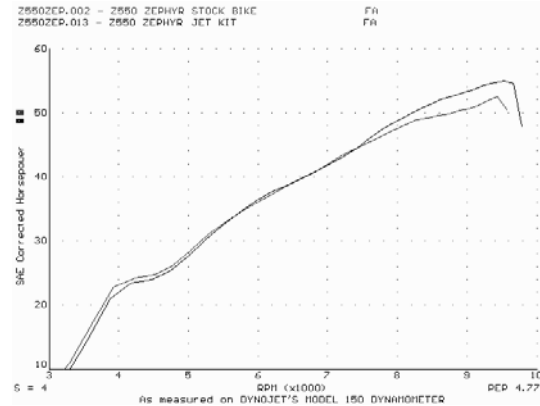

This graph shows a typical gain with a Dynojet jet kit.

WARNING

**NO SMOKING!
 NO OPEN FLAME!
 WHILE INSTALLING
 YOUR DYNOJET KIT**

Parts List		
4	Main Jets	DJ076
4	Main Jets	DJ080
4	Main Jets	DJ106
4	Main Jets	DJ110
1	Slide Drill	DD #7/64
4	Fuel Needles	DNO110
4	E-Clips	DE0002
1	Plug Drill	DD #5/32
1	Screw	DS0001

STAGE ONE INSTRUCTIONS

1. Remove the vacuum slide from the carbs. Remove the stock needles & spacers, noting the order of assembly.
2. Use the slide drill (DD #7/64) provided to enlarge the slide lift hole (Fig. A).
3. Install the Dynojet needles on groove #3, using all stock spacers (Fig. A). There are no adjusting washers for this kit.
4. Remove the main jet and replace with the Dynojet main jets provided. Use the DJ076 main jets with stock exhaust, or use the DJ080 main jets with aftermarket headers or slip-ons with free flowing baffles. Be sure that the jets you are changing are the main jets.
5. Locate the fuel mixture plug (Fig. B), if you see a screw head, proceed to adjusting procedure. With the plug drill (DD #5/32) provided, carefully drill thru the plugs. *NOTE: the mixture screw is directly underneath this plug, be ready to pull back on the drill the instant you break through.* Use screw provided to secure and remove the plug. Carefully turn mixture screw clockwise until seated, then back out 2-1/2 turns.

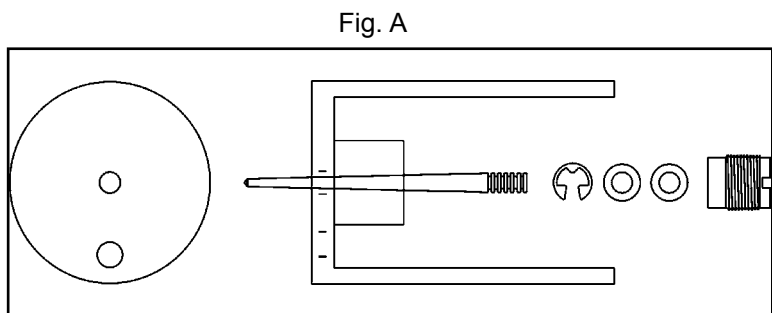

STAGE THREE INSTRUCTIONS

1. Remove the vacuum slide from the carbs. Remove the stock needles & spacers, noting the order of assembly.
2. Use the slide drill (DD #7/64) provided to enlarge the slide lift hole (Fig. A).
3. Install the Dynojet needles on groove #2, using all stock spacers (Fig. A). There are no adjusting washers for this kit.
4. Remove the main jet and replace with the Dynojet main jets provided. Use the DJ106 main jets with stock exhaust, or use the DJ110 main jets with aftermarket headers or slip-ons with free flowing baffles. Be sure that the jets you are changing are the main jets.
5. Locate the fuel mixture plug (Fig. B), if you see a screw head, proceed to adjusting procedure. With the plug drill (DD #5/32) provided, carefully drill thru the plugs. *NOTE: the mixture screw is directly underneath this plug, be ready to pull back on the drill the instant you break through.* Use screw provided to secure and remove the plug. Carefully turn mixture screw clockwise until seated, then back out 2-1/2 turns.

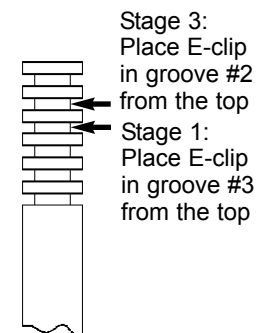
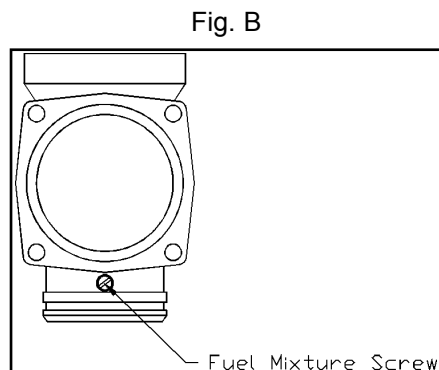

Dynojet

2107.003